

INSTALLATION MANUAL

Kamstrup 382M



Kamstrup

Installation manual

Connect the meter in accordance with the installation diagram on the meter's type label. Depending on the configuration a fixed value will be displayed, or the display will change between selected indications every 10 seconds.

It is possible to change the display reading manually by activating the push button on the meter. The available readings will depend on the meter's configuration.

Security and installation guidelines

The meter is only to be used for measuring electrical energy and shall operate within the specified values only.

The meter must be disconnected when working on it. It can be highly dangerous to touch the meter parts when the meter is switched on.

Therefore, the relevant security fuse must be removed and kept in a place where it cannot be inserted by unauthorized persons.

Current local standards, guidelines, regulations and instruction must be observed. Only authorized personnel is permitted to install electricity meters.

Meters for direct connection must be protected against short circuit by a security fuse in accordance with the maximum current stated on the meter.

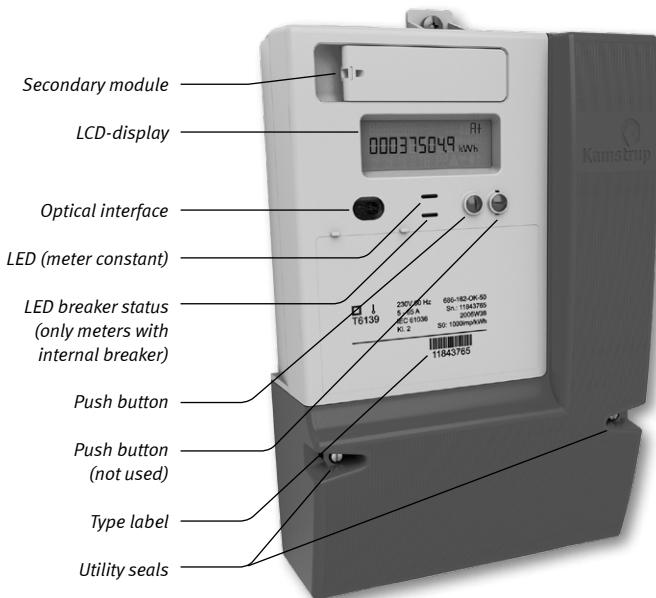

The meter constant LED blinks proportionally to the consumed active energy. Only authorized personnel must break the utility sealing.

Installation manual

The phase indications have various functions. They indicate the two situations described below.

From the connection of the meter:

Indications L1, L2, L3	Indicate
On	Voltage is above minimum limit (160V)
Off	Voltage is below minimum limit (160V)
Indications 	Indicate
On	The load is above the minimum (2,3W)
Off	The load is below minimum limit (2,3W)

If the load exceeds the minimum limit and the meter is configured with this reading, consumption will be indicated via the quadrant reading. The direction of the three phase currents is indicated via the arrows above, respectively L1, L2 and L3.

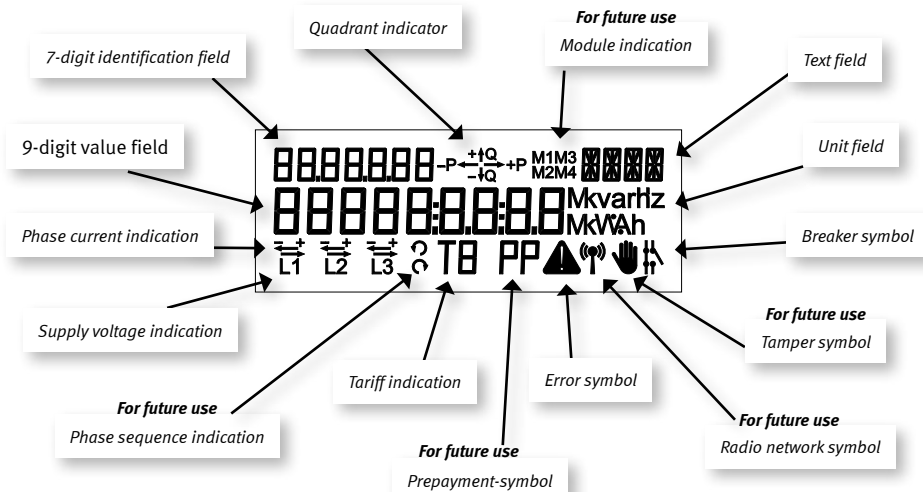

Terminals

	Multi core	7 core	Massive / terminals
35 mm ²	≥ 6 mm ²	≥ 6 mm ²	≥ 2,5 mm ²

Screw: Pz 2 or straight slot

Torch: 2,5 – 3 Nm

Installation manual

With built-in radio

If the meter is supplied with integral radio for establishment of remote reading, the meter automatically connects to a radio network. The integral radio is equipped with an internal antenna. The radio signal strength can be read by means of a hand-held terminal. If the radio signal is not sufficient, an external antenna must be connected. Please see current documentation on available antennas.

Mounting a communication module in the meter may influence on radio communication, please contact Kamstrup.

With disconnection function

With this type of meter, it must be checked that the red/green diode is not switched on. This indicates that the consumer's supply is switched off.

Installation dimensions

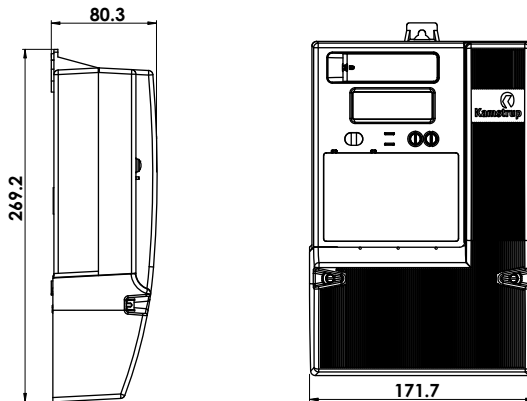

Connection diagrams

The valid connection diagram appears from the type label.

