

Touch Panel Computer – The PANEL COMPUTER series

PT-S959W10

Fanless Touch Panel PC
Atom D2550, 2x LAN,
2x COM, SATA Drive bay



Feature

Silent fanless design with thinner chassis

New generation dual-core CPU with high-performance and power-saving Intel® Atom™ processor D2550

Dual LAN / 4x USB2.0 / 2x COM / 1x Cfast and other rich expansion interface

External DVI display output with 1080p Full-HD support, GMA3650 graphics accelerator

Easy replacement of the storage device 2.5-inch SATA drive bay

10.1 inch wide LCD with Touch Screen
Long-life and Power Saving by LED Backlight.

– The 15"/12" panel-mount model is available. –

Ordering Information

PT-S959W10-DC6000 10.1" panel-mount, Atom D2550, 2GB DDR3

PT-S959W10-DC6100 10.1" panel-mount, Atom D2550, 2GB DDR3, SATA HDD

Physical dimension

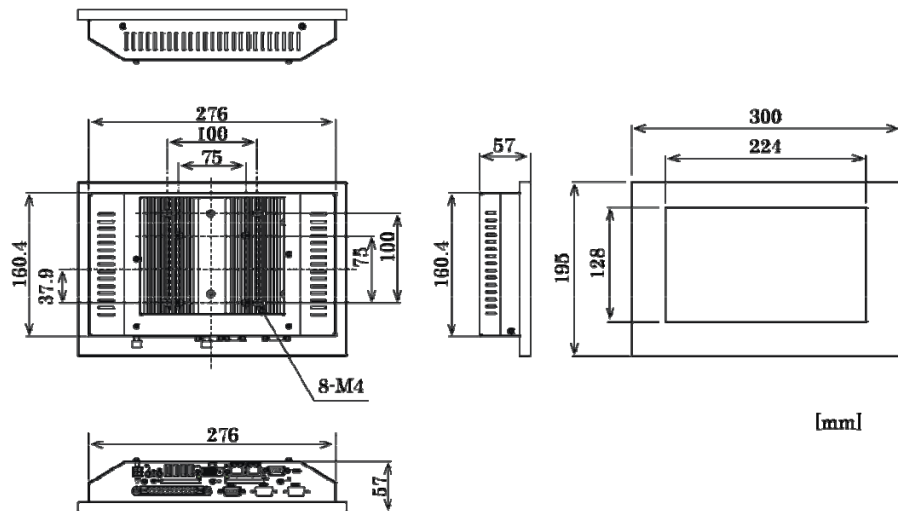

[mm]

Specification

		PT-S959W10
System	CPU	Intel Atom Processor D2550 1.86GHz
	BIOS	AMI BIOS
	Chipset	Intel Atom D2550 + Intel NM10
	Memory	2GB, 1 x 204pin SO-DIMM socket , Max. Capacity 4GB
	Watchdog timer	Software programmable, 255 level (1 - 255 seconds), Reset occurs when the time is up
	Hardware monitor	CPU Temperature, Board Temperature, Power monitor
	RTC/CMOS	Backup battery life : 7 years or more lithium Precision RTC (25°C) : ±3min/Mon (RTC integrated in NM10)
	Power management	Power management setup by BIOS Power On by Ring/Wake On Lan function PC98/PC99 ACPI Power Management Support
Storage	HDD	1 x 2.5-inch SATA drive bay
	SSD(CFast)	1 x External CFast socket(Type I, bootable)
I/O	Video(external output)	1 x DVI-I
	Serial ports	2 x RS-232C ports
	USB ports	4 x USB ports, USB 2.0 compliant
LCD panel	10.1-inch TFT-LCD, XGA(1024×600), 260,000 colors	
Touch panel	Analog resistive, 2048 x 2048 (Emulation in the 1024 x 600), Internal USB connection	
Graphics	Chipset	Intel Atom D2550
	VGA	Up to 1920 x 1200 (16.77M colors)
	DVI	Up to 1920 x 1200 RB (16.77M colors)
Audio	Interface	HD Audio compliant, Line-out, Mic-in
Ethernet	LAN1	10/100/1000 Mbps Realtek 8111E controller, support Wake On Lan
	LAN2	10/100/1000 Mbps Realtek 8111E controller, support Wake On Lan
Power	Input voltage range	12 - 24VDC
	Consumption	12V 3.2A (Max.), 24V 1.6A (Max.)
Mechanical	Dimension(mm)	300(W) x 57(D) x 195(H) (excluding protrusions)
	Panel cut (mm)	224(W) x 128(H)
	Ambient temperature	0 - 50°C
Environment	Storage temperature	-10 - 60°C
	Ambient humidity	10 - 90%RH (Non-condensation)
	Dust-proof, splash-proof	Compliant with IP65 (front panel)
	Line noise	AC line/±2kV, Signal line/±1kV (IEC61000-4-4 Level 3, EN61000-4-4 Level 3)
	Durable electrostatic	Contact/±4kV (IEC61000-4-2 Level 2, EN61000-4-2 Level 2) Air/±8kV (IEC61000-4-2 Level 3, EN61000-4-2 Level 3)
	Vibration	HDD operating : 10 - 50Hz/ 0.5G acceleration peak to peak, XYZ direction 25min (Compliance IEC60068-2-6) HDD non-operating : 10 - 57Hz / 0.15mm single amplitude displacement, 57 - 500Hz/2.0G acceleration peak to peak, XYZ direction 40min (Compliance IEC60068-2-6)
	Shock	10G XYZ direction 11ms half sine wave (Compliance IEC60068-2-27)
	Ground	Grounding D (Old class 3 grounding), SG-FG / conduction
	Standard	CE, FCC, RoHS directive

Contec Global Network

Japan (Headquarters)

Contec Co., Ltd.
3-9-31, Himesato, Nishiyodogawa-ku,
Osaka 555-0025, Japan
Tel : 81-6-6477-5219
Fax : 81-6-6477-1692
E-mail : intsales@contec.jp

USA

Contec Microelectronics U.S.A. Inc.
650 Vaqueros Avenue Unit C,
Sunnyvale, CA 94085 USA
Tel : 1-408-400-8700
Fax : 1-408-400-9115
E-mail : sales@contecusa.com

TAIWAN

CONTEC Solution Co., Ltd.
2FL-3, No. 738, Zhongzheng Road,
Zhonghe District, Xinbei 23511 TAIWAN
Tel : 886-2-8228-0298
Fax : 886-2-8228-0098
E-mail : sales@contecsolution.com

CHINA

CONTEC Solution China Corporation
Room 1002, Qilai Building, No. 889,
Yishan Road, Shanghai 200233 CHINA
Tel : 86-21-5401-2288
Fax : 86-21-5401-2287
E-mail : marketing@contec.com.cn