

## M-BUS pulse counter type MBHL-.....

## M-BUS Series

### Instruction Manual

MBHL is microcontroller-based pulse counter with 2 or 4 pulse inputs and m-bus interface. It is used for connection of tax meters with pulse outputs to an m-bus network (mainly water and heat meters). It can be mounted on the wall, not for DIN-rail. MBHL does not support tariffs. It saves only general number of pulses for every input.

#### 1. Main technical parameters

- pulse inputs	- .....
- m-bus network voltage	- 12-42 Vdc
- network current consumption, max	- 2 mA (1.3 std. m-bus loads)
- display	- none
- keyboard	- none
- pulse frequency, max	- 5-25 Hz programmable, default 10Hz
- input cable length, max	- 15 m, twisted pair
- input NC resistance, max.	- 1 kOhm
- input NO resistance, min	- 1000 kOhm
- storage temperature	- -50÷+90 °C
- air humidity, working	- 40-90 %
- dimensions (H/W/D max)	- 74/74/40mm
- communication parameters	- 300/2400/4800 bps, Odd/Even/No parity, 1 stop bit (2400 8-E-1 default)
- weight	- < 100 g
- battery	- none/ on demand - LiMnO <sub>2</sub> 60mAh (~40-60 days), life 5 years
- default communication settings	- 2400bps, 8-E-1

#### 2. How MBHL works

MBHL turns on automatically with network voltage. Then MBHL starts counting pulses. All the settings like primary network address, medium and unit for every input can be set through the network, but only if MBHL is not locked. MBHL comes from factory with primary network address set to 1, but the user can change it until the device is not locked. Secondary address can also be changed and each input can be set with different address, if this is enabled by special telegram.

If MBHL is ordered without battery (standard), it counts pulses only when it is powered by the network. If the electric power is stopped, MBHL stores pulse counts for every input in non-volatile memory and when the power is back, it reloads these values and continues counting. If MBHL is ordered with battery (option) it can work and count pulses even without m-bus network power for about 40 to 60 days, depending on the pulse parameters.

Pulse counters for every inputs are saved in non-volatile memory every month, regardless of power interruptions and battery presence.

If MBHL is ordered with battery, the battery needs to be replaced every 5 years or after reaching certain number of charge/discharge cycles (these are stored by MBHL). The MBHL itself has MTBF over 250000 (over 25 years), i.e. it does not need replacement with the battery. If the battery is not present, MBHL does not need any maintenance.

#### Setting primary network address

The primary network address of the device is unique number from 1 to 250 and must be different for each device in an m-bus network. The information collecting device communicates with MBHL with this address, so the address must be set first when setting up the network. As MBHL has several pulse inputs, each of them is treated as separate device with different address, so if you set MBHL address to 10, the first pulse input data can be read at address 10, second pulse input data can be read at address 11, third pulse input data can be read at address 12, etc. to the last input. Setting address bigger than 250 is not allowed for any input. The primary address can be changed any time through the network (with primary or secondary addressing) until the device is not locked. After locking the MBHL, setting the address is not allowed anymore and MBHL uses the address, set prior to locking.

#### Turning MBHL off

Turning off MBHL puts it in lowest power mode without pulse counting and is used for transportation and when the devices are mounted, but before setting up the network. Turning off can be done by pressing button inside the enclosure.

Turning off is needed only if battery is inserted; if MBHL has not battery inserted, turning off is meaningless and so the button is not soldered at all. After locking the device, turning it off is not possible.

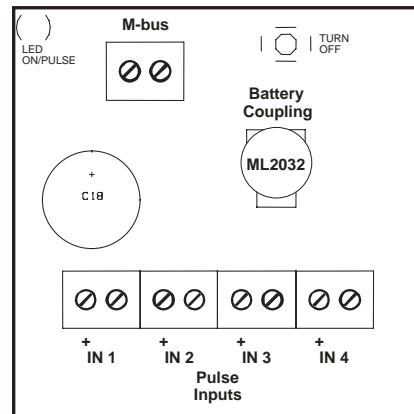

#### 3. Mounting and electrical connections

MBHL can be mounted on standard M35 DIN-rail. Every connection should be made with 0.25mm<sup>2</sup>-1.5mm<sup>2</sup> isolated cables, according to the following table:

No. on the picture	Description
M-bus	m-bus network
IN 1	Non-potential pulse input 1 (not connected if not used)
IN 2	Non-potential pulse input 2 (not connected if not used)
IN 3	Non-potential pulse input 3 (not connected if not used)
IN 4	Non-potential pulse input 4 (not connected if not used)

Max. length of each pulse input cable is 15m for twisted pair 0.5mm<sup>2</sup>.

#### 4. Setting up MBHL

- Step 1: MBHL is mounted and pulse inputs are connected to the MBHL
- Step 2: MBHL is connected to the m-bus network
- Step 3: After connecting every slave device (i.e. MBHL) to the network and powering the main network converter it is possible to set up all the devices in the network. Setting up the parameters can be done with the free MBConfig software.

The following parameters can be set:

- Setting up primary addresses of the devices
- Changing communication parameters – baud and parity (only if needed)
- Set/change secondary address
- Programming medium (cold/hot water, heat, electricity, HCA, etc..)
- Programming the unit (1/imp, 0.01kWh/imp, etc.)
- Programming pulse parameters (duration of pulse and pause) – only if needed
- Locking the devices

After setting the devices up the system is ready to work.

The life of the battery (if inserted) is 5 years from the date of powering the devices. After 5 years are elapsed, the batteries need replacement.

#### 5. Inputs and pulse counting

MBHL has two or four independent inputs for pulse counting, each having unique communication address. Medium and unit can be programmed for every input independently. The pulses are collected in separate arrays for every input. Pulse counts specially of MBHL can be changed through the software. The idea is to have same on counter and water-meter. Pulse counters are stored in non-volatile memory at every power interruption. The data is also save in non-volatile memory once a month.

Maximum pulse frequency can be programmed from 5 to 25Hz through the network. The default value is 10Hz. Higher frequency pulses can be counted incorrectly, if counted at all (pulse missing is probable).

The pulses come from non-potential contact (reed contact) or transistor optocoupler output. In the latter case the polarity must be observed. The minimum resistance of the open contact should be greater than 1 MOhm, while the maximum resistance (including connecting cable resistance) should be less than 1 kOhm. Connecting cable length should be no greater than 25m. It is recommended to use twisted pair cable type.

Counters rollover to zero when value of 99999999 is reached.

#### 6. Warranty

The warranty of the device is limited to 3 years from the date of sale. If the device shows any defect or malfunctions during that period, the manufacturer is obligated to repair the device in its own service for manufacturer's expense, or, if the repair is impossible, to replace the device with the new one. The transportation costs to the manufacturer's service are due to the client. The warranty voids if this manual's instructions are not met, warranty seals are removed or the device was opened by unauthorized by the manufacturer personnel.

Serial/ ID number:.....

Date of sale: .....

Signature: .....

#### 7. Package contains

- MBHL - 1 pc.
- Instruction manual - 1 pc.